

エキスパンドメタル SUS304

単位:mm

| 品番 | メッシュ寸法 | | ストランド寸法 | | 1,000×1,000 | 1,000×2,000 | 1,219×2,438 | 1,524×3,048 |
|-------|--------|-------|---------|-----|-------------|-------------|-------------|-------------|
| | SW | LW | T | W | | | | |
| | 3.1 | 6.0 | 0.5 | 0.7 | ● | | | |
| | 3.0 | 8.0 | 0.5 | 0.7 | | ● | | |
| | 3.0 | 8.0 | 0.6 | 0.8 | | ● | | |
| | 4.0 | 8.0 | 0.5 | 0.8 | ● | | | |
| | 7.0 | 14.0 | 0.5 | 1.0 | | ● | | |
| | 7.0 | 14.0 | 0.6 | 0.8 | | ● | | |
| | 7.0 | 14.0 | 0.8 | 1.0 | | ● | | |
| | 7.0 | 14.0 | 1.0 | 1.0 | | ● | | |
| | 10.0 | 20.0 | 0.8 | 0.9 | | ● | | |
| | 10.0 | 20.0 | 1.0 | 1.0 | | ● | | |
| | 14.0 | 25.0 | 0.8 | 1.0 | | ● | | |
| | 16.0 | 32.0 | 0.8 | 0.9 | | ● | | |
| | 16.0 | 32.0 | 1.0 | 1.1 | | ● | | |
| | 16.0 | 32.0 | 1.2 | 1.2 | | ● | | |
| | 16.0 | 32.0 | 1.5 | 1.7 | | ● | | |
| X-31 | 12.0 | 30.5 | 1.2 | 1.4 | | ● | | |
| X-32 | 12.0 | 30.5 | 1.5 | 1.7 | | ● | ● | |
| X-33 | 12.0 | 30.5 | 2.0 | 2.0 | | ● | ● | |
| X-41 | 22.0 | 50.8 | 1.5 | 1.7 | | ● | | |
| X-42 | 22.0 | 50.8 | 2.0 | 2.0 | | ● | ● | |
| X-43 | 22.0 | 50.8 | 3.0 | 3.0 | | ● | ● | |
| X-61 | 34.0 | 76.2 | 2.0 | 2.4 | | ● | | |
| X-62 | 34.0 | 76.2 | 3.0 | 3.2 | | ● | | |
| X-63B | 34.0 | 76.2 | 4.0 | 4.0 | | ● | ● | |
| X-11 | 34.0 | 135.4 | 4.5 | 6.5 | | ● | ● | |
| X-12 | 34.0 | 135.4 | 6.0 | 6.5 | | ● | ● | |
| X-21 | 36.0 | 101.6 | 4.5 | 6.0 | | ● | ● | |
| X-21C | 36.0 | 101.6 | 4.5 | 5.0 | | ● | ● | ● |
| X-22 | 36.0 | 101.6 | 6.0 | 6.0 | | ● | ● | ● |

●エキスパンドメタル各部の名称

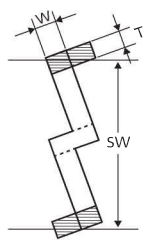
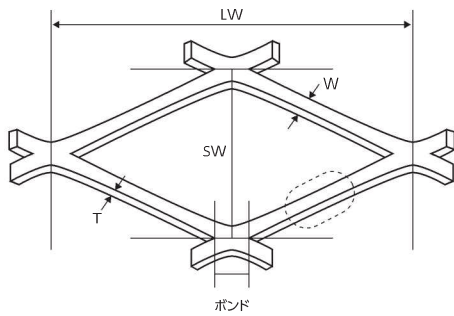

SW : メッシュ短目方向の中心間距離
 LW : メッシュ長目方向の中心間距離
 T : 板厚
 W : 刻み巾